

with Installation Instructions

Owner's Manual

Banks Split-Dual Monster[®] Exhaust System

**2001-2007 Chevy/GMC
6.6L Duramax (LB7, LLY, LBZ)
Turbo-Diesel Pickups**

THIS MANUAL IS FOR USE WITH SYSTEMS
48670-48675, 48942-48946

Gale Banks Engineering
546 Duggan Avenue • Azusa, CA 91702
(626) 969-9600 • Fax (626) 334-1743

Product Information & Sales: (800) 438-7693
Customer Support: (888) 839-5600
Installation Support: (888) 839-2700

bankspower.com

General Installation Practices

Dear Customer,

If you have any questions concerning the installation of your Banks Monster Exhaust System, please call our Technical Service Hotline at (888) 839-2700 between 7:00 am and 5:00 pm (PT). If you have any questions relating to shipping or billing, please contact our Customer Service Department at (888) 839-5600.

Thank you.

1. Before starting work, familiarize yourself with the installation procedure by reading all of the instructions.
2. The exploded view (**Figure 1**) provides only general guidance. Refer to each step and section diagram in this manual for proper instruction.
3. Throughout this manual, the left side of the vehicle refers to the driver's side, and the right side to the passenger's side.
4. Disconnect the negative (ground) cable from the battery (or batteries, if there are two) before beginning work.
5. Route and tie wires and hoses a minimum of 6" away from exhaust heat, moving parts and sharp edges. Clearance of 8" or more is recommended where possible.
6. When raising the vehicle, support it on properly weight-rated safety stands, ramps or a commercial hoist.

Follow the manufacturer's safety precautions. Take care to balance the vehicle to prevent it from slipping or falling. When using ramps, be sure the front wheels are centered squarely on the topsides; put the transmission in park; set the hand brake; and place blocks behind the rear wheels.

Caution! Do not use floor jacks to support the vehicle while working under it. Do not raise the vehicle onto concrete blocks, masonry or any other item not intended specifically for this use.

7. During installation, keep the work area clean. Do not allow anything to be dropped into intake, exhaust, or lubrication system components while performing the installation, as foreign objects will cause immediate engine damage upon start-up.

Tools Required:

- 1/2" and 3/8" drive ratchets with standard and metric sockets and 1/2" and 3/8" drive extension
- Standard and metric combination or open-end wrenches
- Standard screwdriver
- Clean shop towels or rags
- Pry-bar

Highly recommended tools and supplies:

- Foot-pound torque wrench
- Penetrating oil or light lubricant spray
- Reciprocating saw

Exhaust System Installation

1. As a precaution, disconnect the ground of the battery (if there is more than one battery, disconnect both).

2. Raise the vehicle and support it with properly weight rated safety stands, ramps or a commercial hoist. Follow the manufacturer's safety precautions. Take care to balance the vehicle to prevent it from slipping or falling. When using ramps, be sure the front wheels are centered squarely on the topsides; place the transmission in park; set the parking brake and place blocks behind the rear wheels.

CAUTION: DO NOT WORK UNDER ANY VEHICLE SUPPORTED ONLY BY A JACK. SEVERE INJURY MAY RESULT.

3. Removal of the factory exhaust can be simplified by cutting the factory exhaust pipe behind the muffler. This will allow the tailpipe to be removed as a separate piece.

4. For 2006-2007 models, remove the clamp located on the catalytic converter outlet.

5. For 2001-05 models, remove the four (4) nuts from the factory exhaust flange located at the back side of the factory head pipe (retain for re-use).

6. Remove the factory tailpipe from the vehicle by disengaging the exhaust system hanger pins from the rubber hangers using a large screw-driver or pry bar. *Note: Lubricating the rubber hangers with WD-40 or similar lubricant will ease removal of the hanger pins.*

7. Remove the factory muffler from the vehicle by disengaging the hanger pins from the rubber hangers using a large screwdriver or pry bar.

*NOTE: If Banks Headpipe (system 48670, 48671 or 48672) is being installed, perform **steps 8 thru 11** below. Otherwise continue installation with **step 12**.*

8. On the front of the exhaust, spray penetrating oil such as WD-40 on the T-bolt of the factory V-band clamp to prevent galling. Remove factory V-band clamp and save for re-use.

9. Remove factory head pipe from the vehicle by disengaging the exhaust system hanger pins from the rubber grommets using a large screwdriver or pry bar.

10. Install Banks head pipe in vehicle and insert the hanger pin in the rubber exhaust grommet. *NOTE: Be sure to install the hanger pin in the same location as the previously removed factory head pipe.*

11. Loosely install the V-band clamp on head pipe flange and only tighten the T-bolt on the clamp to the point that the pipe is snug but can still be rotated in the clamp for adjustment/alignment. *NOTE: Do not completely tighten the V-band clamp at this point.*

*NOTE: proceed to **step 14** for 2006-2007 models installation instructions*

CAUTION: The following step involves cutting a stainless steel tube. Safety glasses should be worn during any cutting operation and care should be taken to avoid injury due to sharp edges and burrs.

12. If the system is being installed on an extended-cab long-bed or an extended-cab short-bed vehicle, the Banks flanged intermediate pipe (53717) must be trimmed prior to installation in the vehicle. For extended-cab long-bed models, trim 9-1/2" from the outlet of the intermediate pipe such that 10" including the flange is remaining. Once the cut has been performed, debur the cut end with a file or sandpaper. (See **Figure 2**).

Figure 1, General Assembly

	Description	P/N
1	Optional head pipe (1)	53716
2	4-bolt gasket (1)	93210*
3	Flanged Intermediate pipe (1)	
	All Ext.cabs and Crew cabs	53717*
	Std. cab, long bed	53713*
4	4" Band clamp (1)	52471*
5	2001-2005 Intermediate pipe (1)	
	Std. cab, long bed	53721*
	Ext.cab, short bed/Crew cab, short bed	53724*
	Ext. cab, long bed/Crew cab, long bed	53725*
5a	2006-2007 Intermediate pipe (1)	
	Std. cab, long bed	53738
	Crew cab, short bed	53740
	Ext.cab, long bed	53741
	Crew cab, long bed	53742
6	4" Saddle clamp (1)	52476
7	Monster muffler (1)	53800
8	Rear muffler hanger/clamp (1)	53726
9	Y-pipe, Split dual (1)	53727
10	3.5" Saddle clamp (2)	52468
11	Driver side tailpipe (1)	53743
12	Passenger side tailpipe (1)	53744
13	Driver side frame hanger bracket (1)	53731
14	Driver side rubber hanger (1)	53732
15	1/2-13 x 1.0" Bolt (2)	91930
16	1/2 SAE washer (4)	91902
17	1/2-13 Nylock nut (2)	91823
	Description	P/N

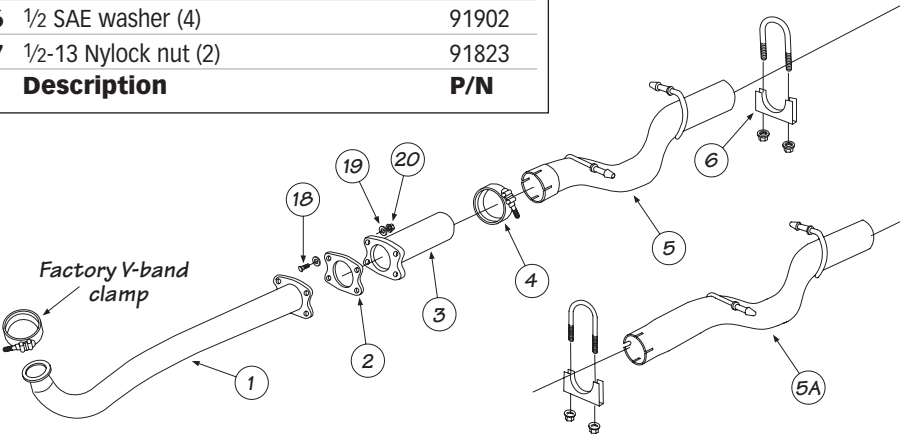

18	7/16-20 x 1.0" Bolt (optional) (4)	91629*
19	7/16 SAE washer (optional) (8)	91601*
20	7/16-20 Crimplock nut (optional) (4)	91619*
21	5" Black cable tie (3)	62001
22	Banks decal (2)	96009
	Owners Manual (1)	96439
	Warranty statement (1)	96503

*Parts exclude 2006-2007 models

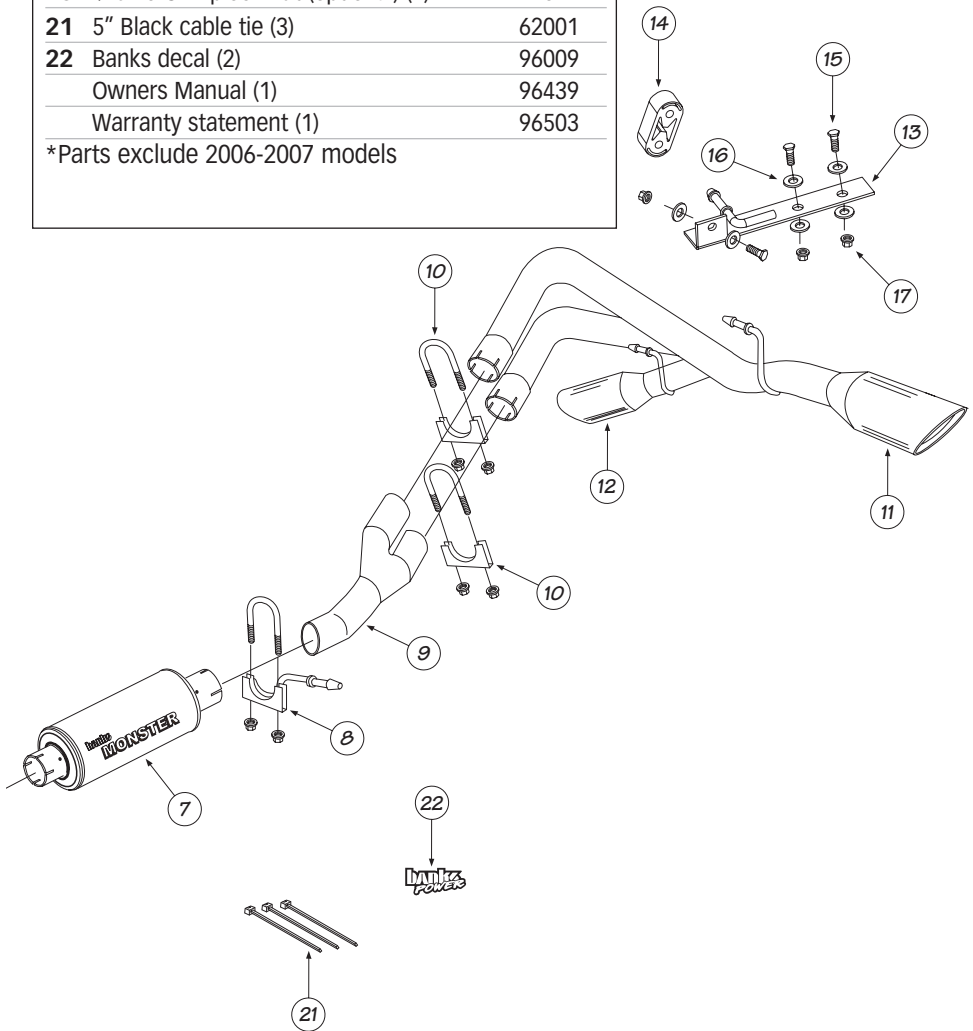

Figure 2

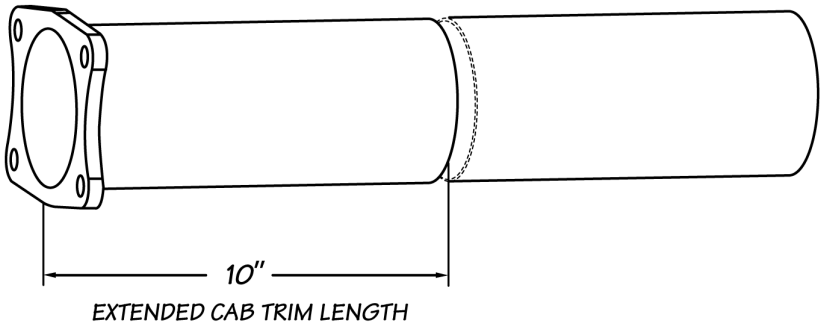
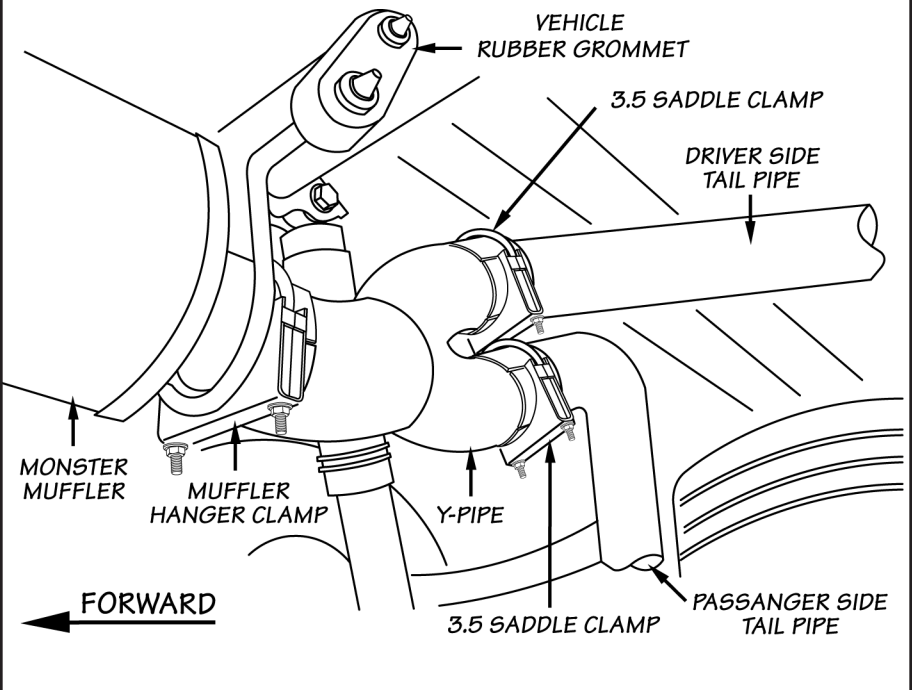

Figure 3



13. Install the Banks flanged intermediate pipe and 4-bolt gasket onto the headpipe. Loosely assemble with the four (4) factory nuts or if optional headpipe was installed use the supplied $7/16$ " bolts, washers and nuts. Slide the Banks 4-inch band clamp on the outlet of the Banks 4-bolt flange pipe.

14. For 2006-2007 models, install a 4" saddle clamp onto the catalytic converter outlet.

15. Insert the intermediate pipe inlet onto the flanged intermediate pipe or catalytic converter outlet. Install the intermediate pipe hanger pin(s) into the vehicle rubber grommets.

NOTE: Once the pipe has been completely engaged in the slip joint, it should be marked with a marker, scribe or tape for reference when tightening clamps later in the installation. Each slip joint in the system should be marked in this fashion. When the exhaust system is being adjusted to align the hangers, the slip joints can be adjusted so that the reference mark is no more than $1/4$ " away from its original position.

16. Install a 4" saddle clamp onto the Monster muffler inlet. Install the Monster muffler inlet onto the Banks intermediate pipe outlet. Be sure that the inlet side of the muffler (see markings on muffler body) is facing toward the front of the vehicle. Orient the muffler such that the "Banks Monster" logo is facing towards the frame and is level with the ground. Verify that the muffler and intermediate pipe are completely engaged.

17. Install the muffler hanger clamp onto the muffler outlet. Insert the hanger pin into the vehicle's rubber hanger.

18. Install the Banks Y-pipe into the muffler outlet such that the outlets are

pointing up. Install two (2) 3- $1/2$ " saddle clamps onto each y-pipe outlet (See **Figure 3**).

19. Install the driver-side hanger bracket into the rear of the driver-side frame rail. If a hitch is installed, remove the hitch hardware on the driver-side, install the frame bracket and reinstall the existing hitch hardware.

For Long bed models, use one (1) bolt on the flat of frame rail and one (1) bolt on the side of the frame rail.

For Short bed models, use two (2) bolts on the flat of the frame rail (no bolts on the side).

See **Figure 4**.

20. Install the supplied rubber grommet onto the Banks hanger bracket.

21. Install the driver-side tailpipe (longer) into the top Y-pipe outlet. Install the driver-side tailpipe hanger into the Banks rubber grommet.

22. Install the passenger-side tailpipe (short) into the lower Y-pipe outlet. Install the passenger-side tailpipe hanger into the vehicle rubber grommet.

23. Adjust each of the pipes to ensure that all of the hanger pins are parallel with the frame mounted pins and that the rubber hangers are all positioned slightly forward (See **Figure 5**). This allows the hangers to be properly positioned once the exhaust system reaches operating temperature.

24. Be sure that the two (2) tailpipes are completely engaged into the Y-pipe. Rotate the tailpipe until the hanger pins are parallel with the frame-mounted pin. Be sure both tailpipe tips look symmetrical. *NOTE: Minimum distance between exhaust tip and body is a half ($1/2$) inch.*

Figure 4

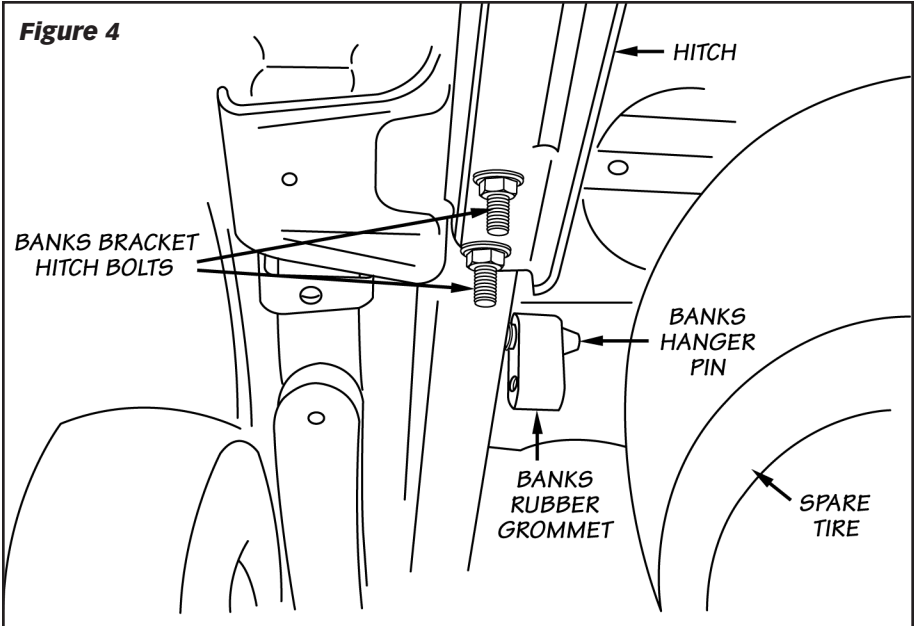

** LONG BED MODELS use only front bracket/hitch bolt and supplied 1/2" bolt on frame rail side*

Figure 5

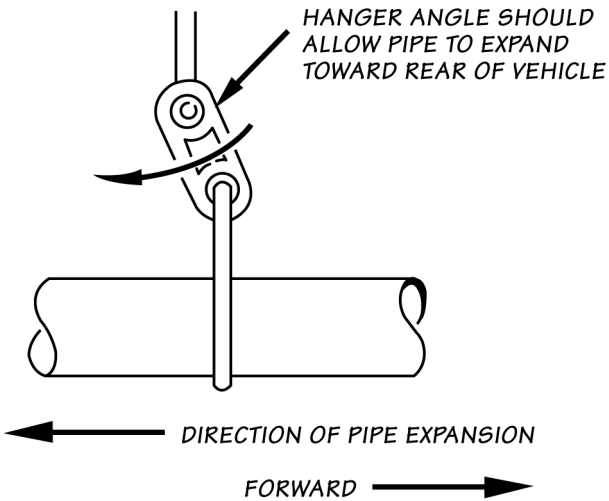

25. Using the three (3) supplied wire ties, tie any hoses, brake lines or harnesses a minimum of four inches away from the exhaust/tail pipes..

26. Tighten the head pipe V-band clamp to 12 ft-lbs (if previously loosened).

27. Align the saddle clamps on the radius of the corresponding pipe slots. **Figure 3** illustrates the proper location of an exhaust clamp on a tubing joint. Torque the nuts on each of the exhaust clamps to 35 ft-lbs. Torque the four (4) factory flange nuts, previously removed, to 30 ft-lbs. Torque the hanger bracket $\frac{1}{2}$ " hardware to 65 ft-lbs. *NOTE: If Banks Head pipe was installed, torque $\frac{7}{16}$ hardware on 4-bolt flange and torque to 48 ft-lbs.*

28. Remove the protective covering from the tailpipe tip.

Caution: the protective covering may ignite and burn if not removed prior to running the engine.

29. Your system includes two (2) Banks Power decals designed to complement the Duramax emblems on the vehicles front doors.

30. Re-connect the negative battery cable. Start the engine and listen for exhaust leaks. Tighten the exhaust clamps as necessary. Whenever possible, tack weld slip connections to prevent disengagement is recommended.

31. The Monster exhaust system installation is now complete.

NOTES

NOTES

Gale Banks Engineering
546 Duggan Avenue • Azusa, CA 91702
(626) 969-9600 • Fax (626) 334-1743

Product Information & Sales: (800) 438-7693
Customer Support: (888) 839-5600
Installation Support: (888) 839-2700

bankspower.com