



20904  
04/22/03  
REV-A

## INSTALLATION INSTRUCTIONS EXTEND-A-FENDER

### TOOLS REQUIRED FOR INSTALLATION:

- Electric Drill
- Jack and Jack Stands (Optional)
- #2 Phillips Driver Bit
- 6" wide Putty Knife
- Utility Knife

### IMPORTANT: READ BEFORE BEGINNING INSTALLATION

**Verifying Fit** - Flares should be held to the vehicle surface to verify correct type and fit BEFORE beginning installation or painting. The inner flare edge should be in contact with the wheel well rim, and the outer flare edge should conform to vehicle fender contours. Small fit adjustments can be made by trimming (filing, sanding or scraping) excess plastic.

**Performance** - Using larger tires may increase the area required to turn the vehicle. Some Tire/Rim combinations may require lowering bump stops and/or installing steering stops to prevent tire shoulders from contacting flare.

**Exhaust System** - Modifications may be necessary to maintain a minimum 4" clearance between flares and exhaust pipes. Exhaust gases should not vent directly onto flares.

---

## FLARE INSTALLATION PROCEDURES

### Step 1: Painting

It is recommended that painting (when desired) be done prior to installation.

- (A) Sand (optional) before application of paint.
- (B) Clean outer surface with a good grade degreaser. DO NOT USE LACQUER THINNER OR ENAMEL REDUCER AS A DEGREASER. Wipe outer surface thoroughly with a tack rag prior to painting.
- (C) Paint flares using a high quality lacquer, enamel, or polyurethane automotive paint. Application of a primer coat is optional.
- (D) If painting edge trim (not recommended) use a flex additive.

### Step 2: Preparing the Work Area (Front and Rear)

- (A) Support and remove wheel using jack and jack stands. (Optional)
- (B) Remove factory fender trim and mud flaps (when installed).
- (C) Trim body side molding (when installed) so flare fits base sheet metal. See Illustration #3.
  1. Hold flare up to wheel well opening and mark body side molding where flare overlaps.
  2. Remove flare.

3. Mark cut line 1/4" beyond overlap line.
4. Use blow dryer to heat molding.
5. Slide 6" wide putty knife between the molding and body of vehicle.
6. Carefully cut on marked line with a utility knife, using the putty knife as a guard against the vehicle.
7. Sand molding to desired finished edge.

### Step 3: Edge Trim Installation (See Illustration #1)

- (A) Peel two to three inches of red vinyl backing away from edge trim tape and affix to outer edge of flare at one end.
- (B) Press edge trim into place along edge of flare in one-foot increments, pulling red vinyl backing free as you continue to work your way around the flare.

### Step 4: Flare Installation (See Illustration #2)

- (A) Hold flare in place on fender.
- (B) Applying moderate pressure to outside surface of flare, fasten with kit supplied drill tip screws using indents in flare as a guide. Drill through the plastic into the sheet metal.

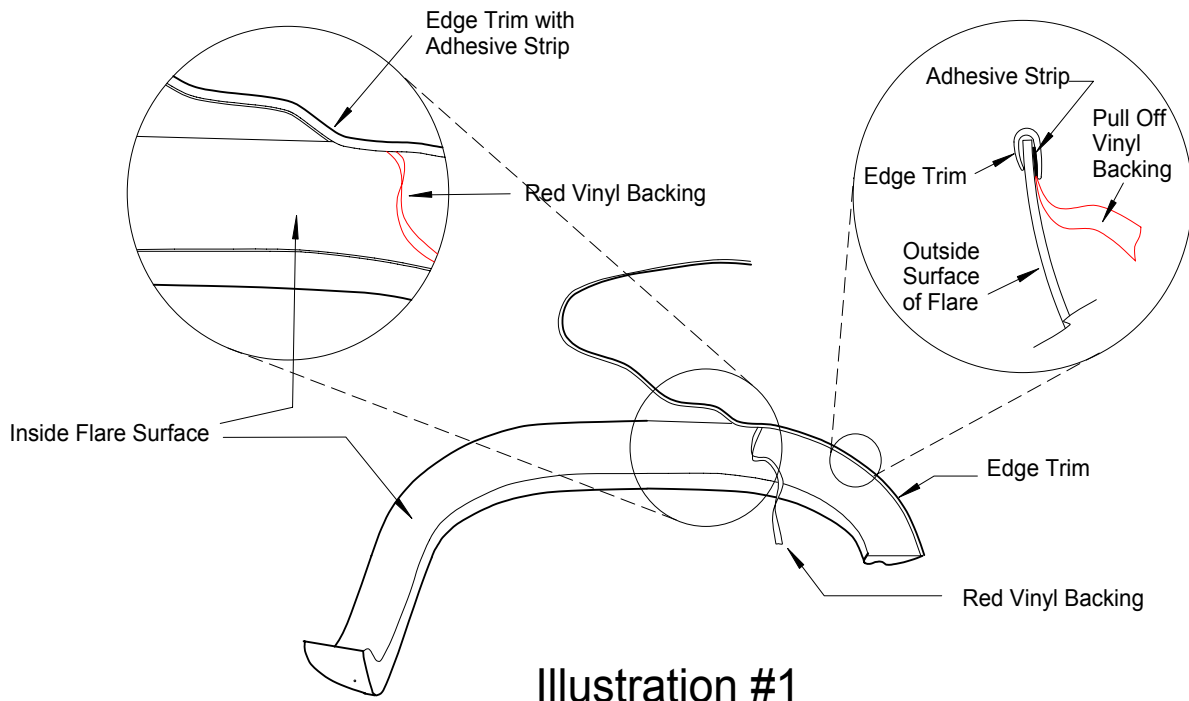

Illustration #1

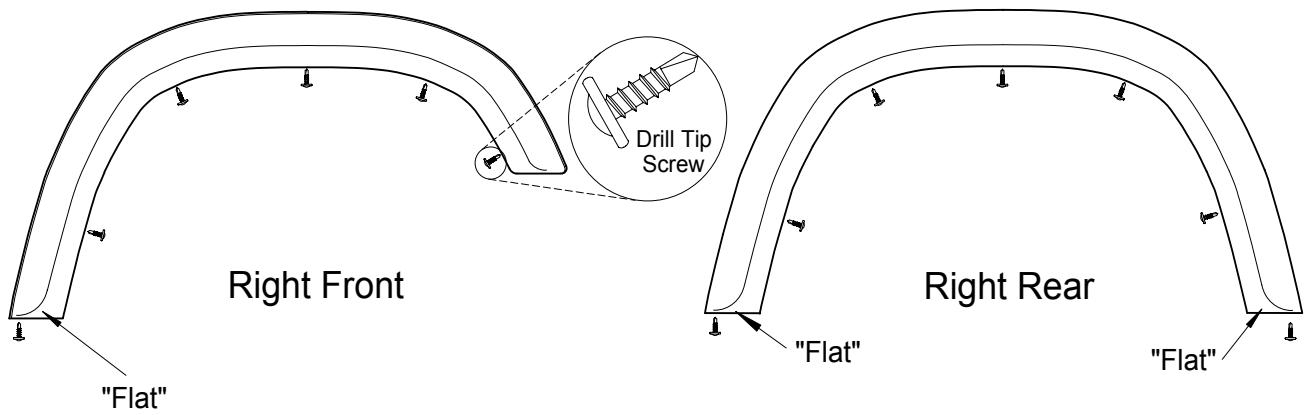

Illustration #2

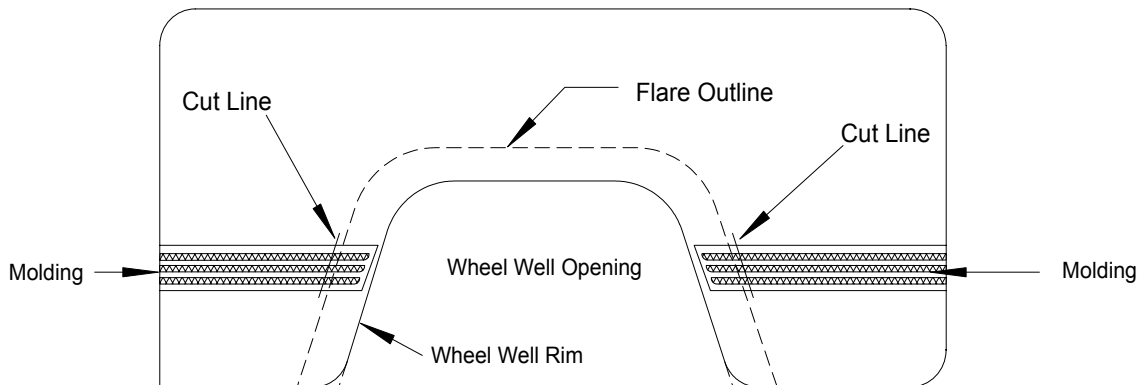

Illustration #3