

# Chevy Pickup 81-91 / Suburban / Blazer

Set Part # 40019

Rev C 3-30-09

## Step 1: Prior to Installation:

- A) Bushwacker only approves installing the flares according to these written instructions with the hardware provided. **WARNING:** Failure to install according to these instructions will invalidate the warranty. This includes, but is not limited to using alternative installation methods, hardware, or materials. **DO NOT USE:** Loctite, SuperGlue, or similar products on the hardware or the flares.
- B) **Fit:** Verify the fit of the flares to vehicle. **(Some filing, sanding, or cutting may be necessary to ensure proper fit).**
- C) **Painting:** (Optional) if paint is desired it must be done prior to installing flares on the vehicle clean outer surface with a good grade degreaser. **DO NOT USE LACQUER THINNER OR ENAMEL REDUCER AS A DEGREASER.** Wipe outer surface thoroughly with a tack rag prior to paint. Paint flares using a high quality enamel, or polyurethane automotive paint. (Application of a primer coat is optional) If painting edge trim (not recommended), use a flex additive.
- D) **Performance:** Using larger Tires may increase the area required to turn the vehicle. Some Tire/Rim combinations may require lowering bump stops and or installing steering stops to prevent tire from contacting flare.
- E) **Exhaust System:** Modifications may be necessary to maintain a minimum 4" clearance between flares and exhaust pipes. (Exhaust gases should not vent directly onto flares)
- F) **Metal Protection:** All exposed fasteners and bare metal should be treated with red oxide primer BEFORE installing flares.



## TOOLS FOR EASY INSTALLATION

- 3/8" Drill Motor
- 1/4" Drill Bit
- #2 Phillips Driver Bit
- Grease Pencil or Marking Pen
- Tape Measure
- Jack Stand and Jack
- Tin Snips
- Sheet metal Cutting Tool (Hacksaw, Sabersaw, Air Chisel, Metal Nibbler, or Air Saw)
- Can of Spray Under Coating
- Rustoleum Red Oxide Primer
- Crescent Wrench
- Small Paint Brush
- Utility Knife
- Clean Wiping Cloth
- Tack Cloth

---

## FLARE INSTALLATION PROCEDURES

### Step 2: Preparing the Work Area (Front)

- A) To work in the wheel well area, remove tire and any other obstructions using jack.
- B) Firmly support vehicle using jack stands.
- C) Remove accent moldings, vehicle emblems, and factory flares from all wheel openings, if vehicle is so equipped. On vehicles equipped with body side moldings that interfere with flare attachments, it will be necessary to modify either the moldings (see Option #1) or the flare (see Option #2). **NOTE: Modifying the flare is more difficult.**

a. **Option 1: MODIFY SIDE MOLDINGS**

Place flare into wheel opening and mark a line across molding where flare intersects. Remove Flare. The molding can be cut on the vehicle by sliding a thin flat piece of metal (putty knife) between the molding and sheet metal. This will shield the paint surface from cuts. Using the line marked as a guide, trim should be cut at an angle which matches flare surface.

b. **Option 2: MODIFY FLARE**

Place flare into wheel opening and mark point of intersection with molding. Remove flare and mark thickness of molding onto flare. Trim (cut, file or grind) flare on marked line.

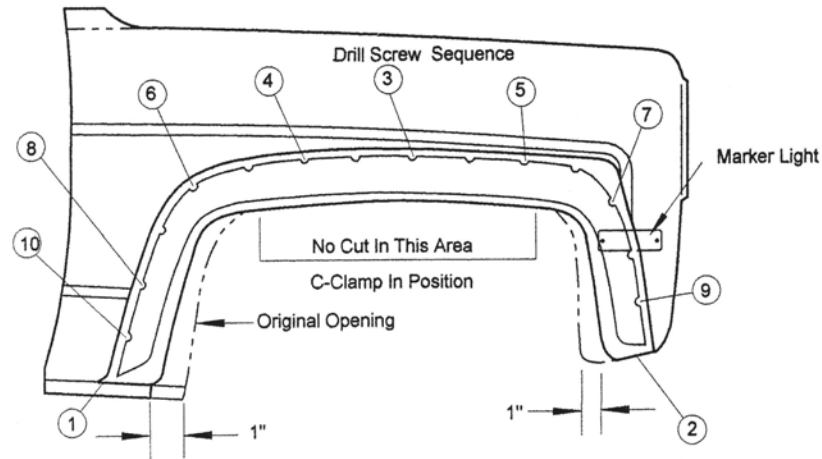

**Illustration #1**

**Step 3: Cutting Sheet Metal (Front)**  
**(See Illustrations #1 & 2)**

- A) Mark a point 1" out from the lower front and lower rear edge of the existing wheel well.
- B) Place appropriate flare on fender, and line up lower inner edges of flare with points marked in Step 3A. Use center edge of wheel well as the stop for inner flange of flare, and align indent on flare to turn signal. Using the inner edge of flare as a guide, mark a line on the fender where existing fender sheet metal extends inside of flare (front and rear). Marked lines should be approximately in line with inner fender well when viewed from the side. **See Illustration #1.**

NOTE: The bumper ends may have to be cut or the whole assembly moved forward to gain flare clearance. Use reciprocating saw to cut bumper; file edge and coat with red-oxide primer.

- C) Cut fender along the lines marked in Step 3B. **Caution should be used to avoid cutting hydraulic, pneumatic, or electrical lines.**
- D) Place flare into cut-out to check fit. If necessary, cut more sheet metal at points of interference to gain proper clearance.
- E) Cutting through the lower forward fender area will separate the outer and inner fender. Outer and inner fenders should be re-secured. Using a supplied drill screw, at lower front corner connect both inner and outer wheel well with drill screw. **See Illustration #2.**
- F) Deburr and coat bare metal with red-oxide primer to prevent rusting.

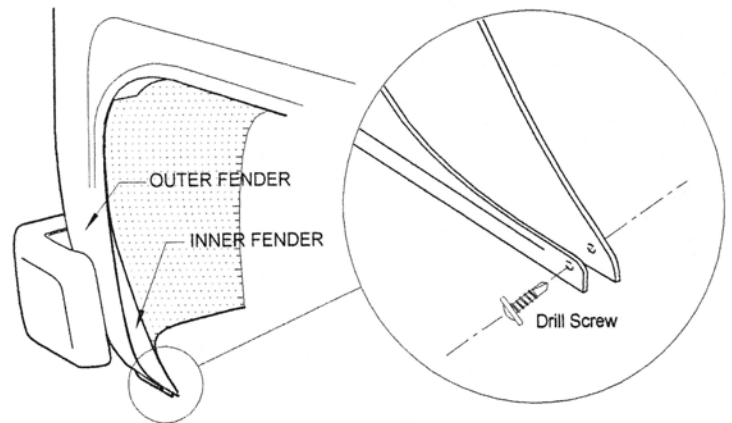

**Illustration #2**

**Step 4: Flare Attachment (Fronts)**  
**(See Illustrations #1 and #3)**

- A) Drill the first hole through the sheet metal using the flare as a guide. **See Illustration #1** for drill screw sequence. Install gimp onto flare edge by sandwiching between the flare and the sheet metal; pierce a hole through the gimp using predrilled hole

as a guide. Secure and continue with Step 4B below. Make sure bulb of gimp is tight against top of flare when securing.

- B) With the flare in place, insert drill screws with a #2 Phillips screw driver. **See Illustration #3** for proper base, drill screw, and cap installation. Drill screws should be installed first at bottom ends, at top center, and then to alternate sides. **See Illustration #1** for drill screw sequence. Use two drill screws (each end) to secure lower front and lower rear flare legs. Install three drill screws through the upper inside lip of the flare to the uncut portion of the wheel well rim.
- C) Reattach the vehicle emblems, removed in Step 2C, at a location that does not interfere with flare.

### Step 5: Preparing the Work Area (Rears)

- A) To work in the wheel well area, remove tire and any other obstructions.
- B) Firmly support vehicle using jack stands.
- C) Remove accent moldings, vehicle emblems, and factory flares from wheel openings, and modify either the moldings or flares as described in Step 2C.

### Step 6: Cutting Sheet Metal (Rears) (See Illustration #4)

**Cutting and fitting instructions for rear flares are generally the same as those described in front flares with a few exceptions:**

- A) The beginning point of the cut line is located and marked 2" out from the lower front and lower rear inside edge of the wheel well opening. The cut line is marked (using the flare as a guide) from the point marked, up to a point on the wheel well opening. **See Illustration #4.**
- B) A fender brace is located at the front of both rear wheel well openings. The bolt securing the brace to the fender must be relocated outside the cut line. After removing the brace bolt and cutting away fender material, a 1/4" bolt hole is drilled 1" forward of the new wheel well edge. The fender brace is bent to align with the new bolt hole and re-secured.
- C) Some vehicles require trimming of the gas door to overcome interference with the flare. The area of interference is marked using the intersection of flare and door. The actual cut line is measured 1/4" out from the line marked to provide necessary clearance. **See Illustration #4.**

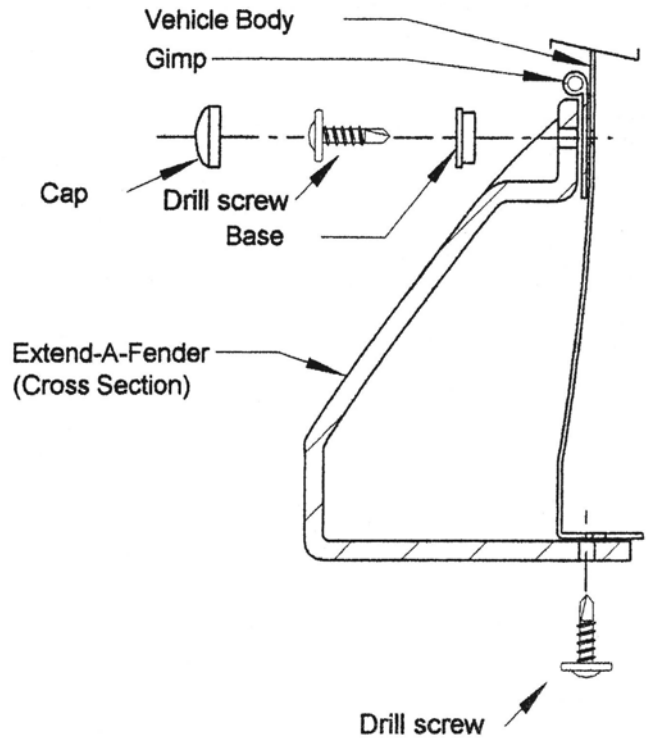

**Illustration #3**

Note: Gas Door May Have To Be Trimmed As Shown

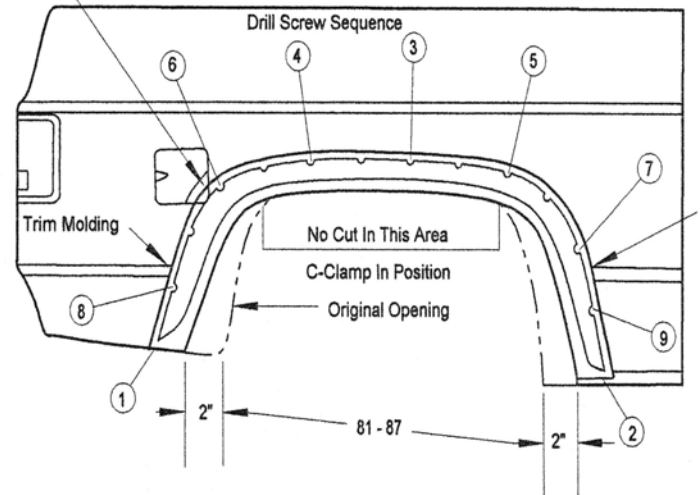

**Illustration #4**

### Step 7: Flare Attachment (Rears) (See Illustrations #3 and #4)

- A) Drill the first hole through the sheet metal using the flare as a guide. **See Illustration #4** for drill screw sequence. Install gimp onto flare edge by sandwiching between the flare and the sheet metal; pierce a hole through the gimp using predrilled hole as a guide. Secure and continue with Step 7B below. Make sure bulb of gimp is tight against top of flare when securing.
- B) With the flare in place, insert drill screws with a #2 Phillips screw driver. **See Illustration #3** for proper base, drill screw, and cap installation. Drill screws should be installed first at bottom ends, at top center, and then to alternate sides. **See Illustration #4** for drill screw sequence. Use two drill screws (each end) to secure lower front and lower rear flare legs. Install three drill screws through the upper inside lip of the flare to the uncut portion of the wheel well rim.
- C) Reattach the vehicle emblems, removed in Step 2C, at a location that does not interfere with flare.