



CUT OUT STYLE FLARES
INSTALLATION INSTRUCTIONS FOR
1982-93 Chevy S-10, 41009, 41010, and 41012
Tools Required for Installation:

- 3/8", 1/4", 3/16", 5/16" Drill Bits
- #2 Phillips Bit
- Hacksaw, Saber Saw, or Air Chisel
- Crescent Wrench
- 3 to 5 lb. Sledge Hammer
- Putty Knife
- Can of Spray Undercoating
- Jack and Jack Stands

IMPORTANT: READ BEFORE BEGINNING INSTALLATION

Bushwacker only approves installing the flares according to these written instructions with the hardware provided. **WARNING:** Failure to install according to these instructions will invalidate the warranty. This includes, but is not limited to using alternative installation methods, hardware, or materials. **DO NOT USE:** Loctite, SuperGlue, or similar products on the hardware or the flares

Verifying Fit - Flares should be held to the vehicle surface to verify correct type and fit BEFORE beginning installation. Small fit adjustments can be made by: (trimming, filing, sanding or scraping) flashing or excess plastic.

Performance - Using larger tires may increase the area required to turn the vehicle. Some Tire/Rim combinations may require lowering bump stops and/or installing steering stops to prevent tire shoulders from contacting flare.

Exhaust System - Modifications may be necessary to maintain a minimum 4" clearance between flares and exhaust pipes. Exhaust gases should not vent directly onto flares.

Metal Protection - All exposed fasteners and bare metal should be treated with red oxide primer BEFORE installing flares.

FLARE INSTALLATION PROCEDURES

Step 1: Painting

It is recommended that painting (when desired) be done prior to installation.

- (A) Sand (optional) before application of paint.
- (B) Clean outer surface with a good grade degreaser. **DO NOT USE LACQUER THINNER OR ENAMEL REDUCER AS A DEGREASER.** Wipe outer surface thoroughly with a tack rag prior to painting.
- (C) Paint flares using a high quality lacquer, enamel, or polyurethane automotive paint. Application of a primer coat is optional.
- (D) If painting edge trim (not recommended), use a flex additive.

Step 2: Disassembly (front) 41009

- (A) Remove wheel and factory flare or wheel well trim (when required).
- (B) Remove entire wheel well liner. See Illustration #1.
- (C) Remove lower support rod at front of fender well. See Illustration #2.
- (D) Remove fender molding only (if so equipped).
- (E) Remove inner locating bolt at lower rear of fender well. See illustration #3.

Step 3: Cutting Sheet Metal (front) 41009

- (A) Mark a point 2" out from front and rear wheel well corners. See Illustration #4.

- (B) Mark a straight line from the points marked in Step 3A to a pint tangent to opening. See Illustration #5
- (C) Place fender flare into fender opening. Using inner edge of flare as a guide, mark inner panel front and rear. See Illustration #6.
- (D) Remove fender flare and mark a cut line 1" outboard from line marked in step 3C. See Illustration #7.
- (E) Cut along lines drawn in Steps 3B and 3D. Remove outer sheet metal. See Illustrations #8 and 9.
- (F) Cut inner panel at rear of fender well to match cut of outer panel. See Illustration #10.
- (G) Relocate lower support rod mounting holes at front of fender well. Using a 1/4" drill bit, drill new mounting holes 1-1/2" forward of original locations. Drill hole for front spoiler also. Do not install support rod at this time. See Illustration #11.
- (H) At rear of fender well, cut tab on inner panel that has a hole which previously held rear of fender. See Illustration #12.
- (I) Reshape panels (both front and rear) of fender well to be flush with cut lines of outer sheet metal. See Illustration #13.
- (J) Using a hammer, re-contour rear footboard sheet metal. The contour should blend with the trimmed sheet metal of the outer panels. One can check proper clearance between the tire and footboard by mounting the wheel and tire combination to be used,

and turning the steering wheel lock to lock. Take into consideration suspension travel when checking clearance. See Illustration #14.

Step 4: Reassemble (front) 41009

- (A) At lower front of fender well, install lower support rod top fasteners. Hand-tighten only.
- (B) At lower rear of fender, measure back 7/8" on lower lip and mark. Center 1/4" drill bit on 7/8" mark and drill through 9/16" spacer. Secure with 1/4" self-locking nut and bolt. See Illustration #'s 15 and 16.
- (C) Trim flange from lower front outboard section of wheel well liner. This will allow clearance for support rod fastener heads. See Illustration #17.
- (D) Reinstall wheel well liner using original fasteners.
- (E) Pull back carpet and pad to expose footboard on inside of cab. From wheel well side, drill (2) 3/16" holes through wheel well liner and footboard sheet metal. See Illustration #18 for drilling locations. Install (2) 3/16" x 3/4" fasteners projecting beyond nuts. This will give a smooth surface when carpet is reinstalled.

Step 5: Fender Flare Installation (front) 41009 and (rears) 41010, 41012

- (A) With flare off the truck, pre-drill all "fastener locating" indents with a 3/16" drill bit. Be careful to avoid flare damage produced by contact with drill chuck. Wrapping the drill bit with tape will serve as a safety stop. See Illustration #19.
- (B) Fit flare tightly into fender well opening, making sure flare contour matches sheet metal contour. Use pre-drilled holes in the flare to serve as drill guides. Drill sheet metal with kit supplied bit and tape depth stop at all pocket locations.
- (C) Using kit provided drill tip screws, attach flares at the outer attachment points first. Use the fastening sequence shown on the illustration sheet. NOTE: Cup washers are used at flare "pockets" only. Continue fastening sequence while maintaining tight contact between flare and sheet metal. See Illustrations #20 and 21.
- (D) Press trim caps onto outer flare fastener cup washers. See Illustration #21.

Step 6: Trimming and Attaching Spoiler (front) 41009

- (A) The original fastener that holds the spoiler to the fender and lower support rod must be modified as per Illustration #22. This will allow clearance to inside wall of spoiler.
- (B) Re-attach spoiler using modified fastener through hole drilled in STEP 3G. Secure all fasteners on lower support rod.
- (C) Trim 2" from spoiler ends even with inside of cut line. See Illustration #23.

Step 7: Disassemble (rear) 41010 and 41012

- (A) Remove wheel and factory urethane flare or wheel well trim (if so equipped). (41010 or 41012)
- (B) Remove lower support rod mounting fasteners (top and bottom) at front and rear of fender well. See Illustration #24. (41010 only)
- (C) Mark a line 2-7/8", front and rear, from wheel well opening on the lower body flange. Drill both locations with 5/16" drill bit. See Illustration #25. (41010 only)
- (D) Bend support rods so that lower holes line up with holes drilled in STEP 8C. Re-attach support rods, front and rear, and secure with original fasteners. (41010 only)

Step 8: Cutting Sheet Metal (rear) 41010

- (A) Mark a line 2" from the lower front and rear of the wheel well opening (both ends).
- (B) Mark a straight line beginning at the points marked in step 8A upward and tangent to the wheel well. See Illustration #26.
- (C) Cut along lines drawn and remove sheet metal.
- (D) If vehicle is equipped with side molding, position flare into wheel well opening and line up over molding. Mark a line across molding at point of interference. Remove flare and side molding. Cut molding on marked line. Re-apply after flare installation (STEP 10).

Step 9: Cutting Sheet Metal (rear) 41012)

Procedures for cutting rear sheet metal for 41012 are the same as those for 41010 with the following exceptions:

- (A) It will be necessary to cut through two panel construction on the rear of the S-10 Blazer model.
- (B) Re-contour the inner panel flush with the trimmed outer sheet metal panel using a 3 to 5 lb. Hammer.
- (C) Seal open spaces and bare metal with spray undercoating where necessary.

Step 10: Fender Flare Installation (rear) 41010 and 41012

Follow STEP 5A through 5D. See Illustration #20 for fastening sequence.

Step 11: Reassembly of Fender Support Rods (rear) 41010

- (A) Adjust lower fender well support rods so that lower portions of the attached fender flares are in line when viewed from the rear of the vehicle. To adjust, loosen the upper fasteners on support rods and move rod in or out. It may be necessary to bend support rods to achieve correct adjustment.

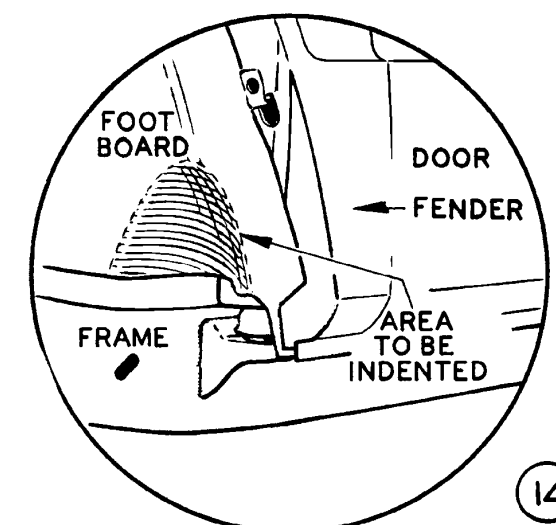
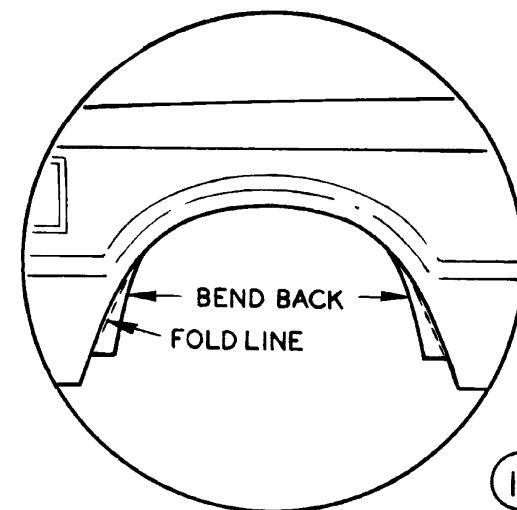
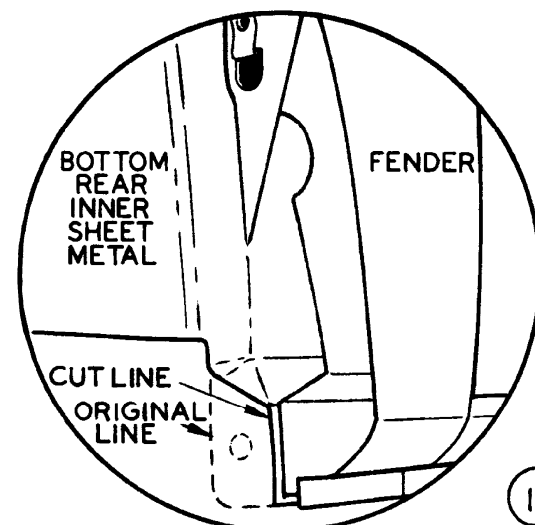
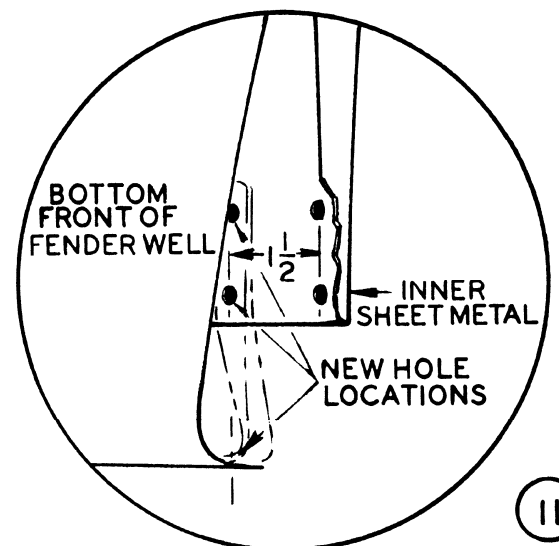
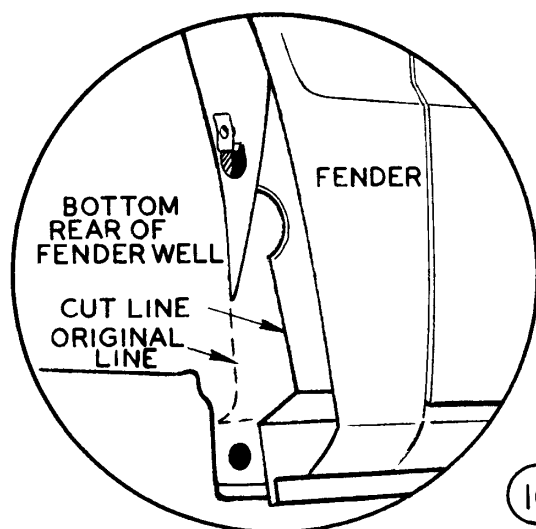
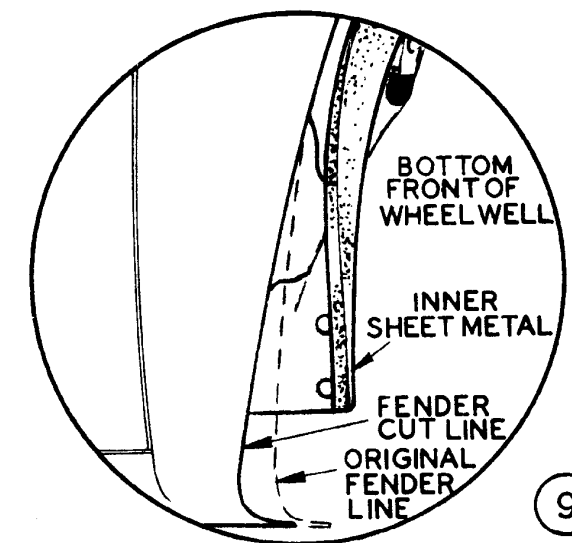
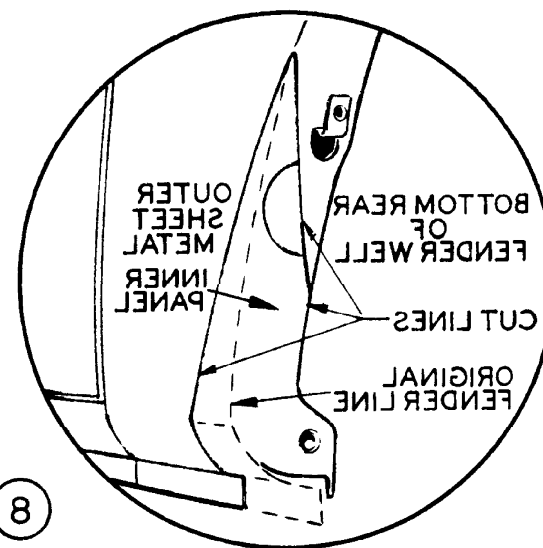
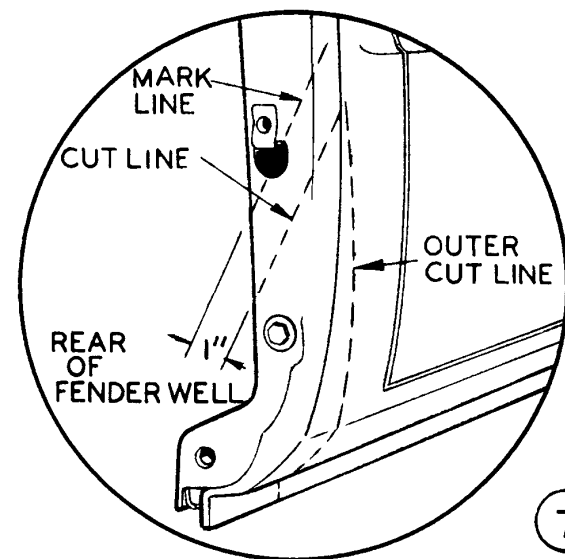
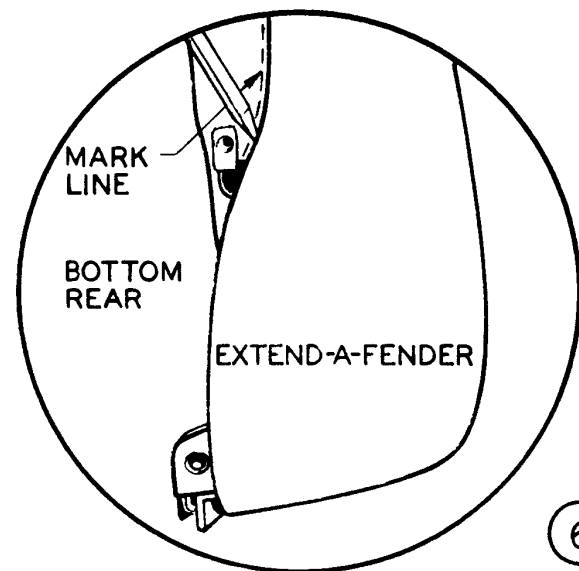
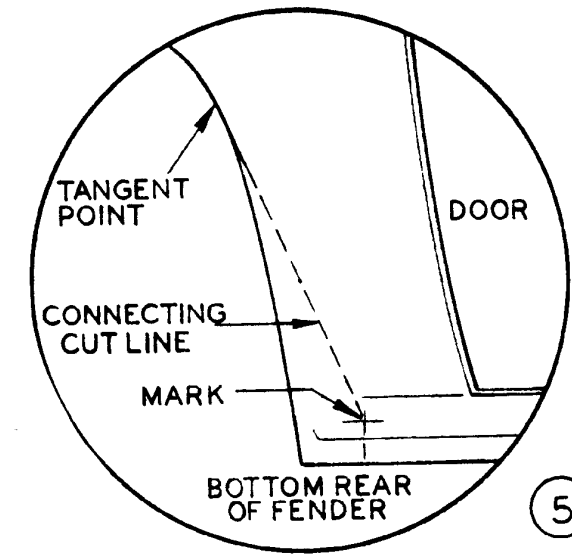
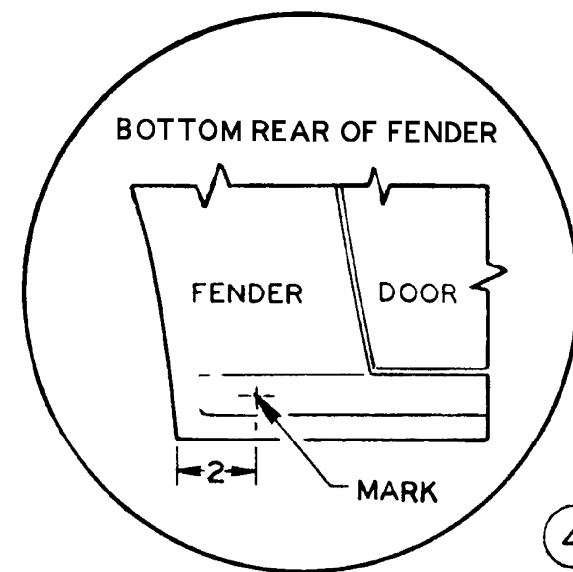
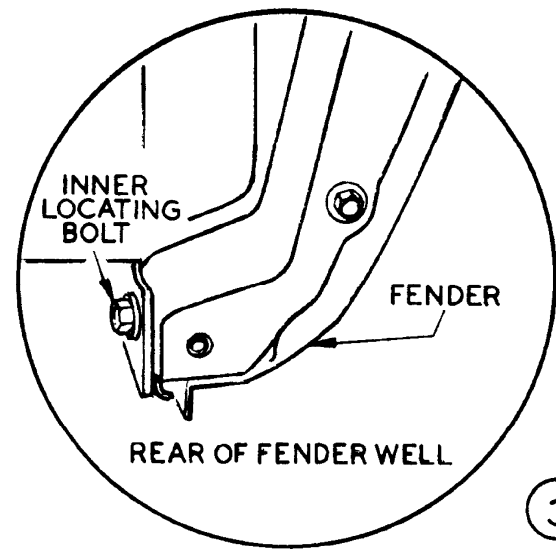
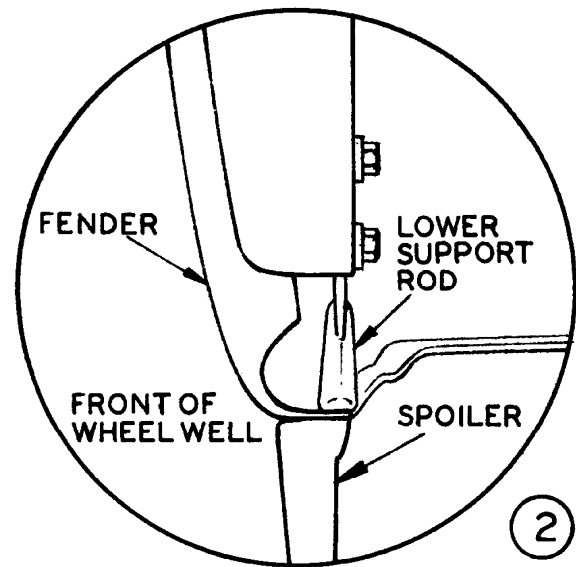
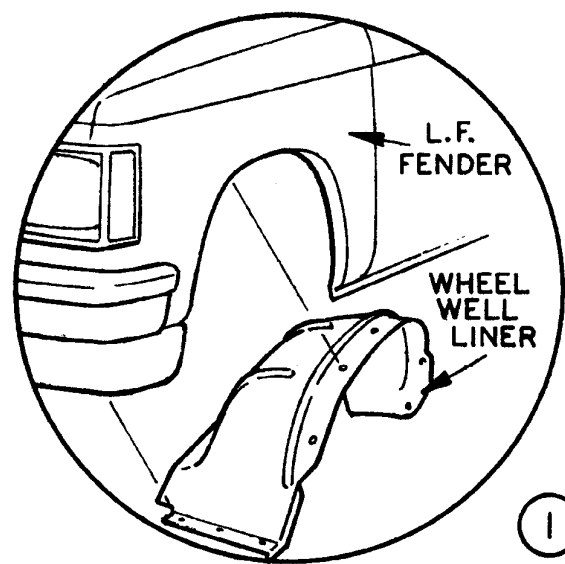

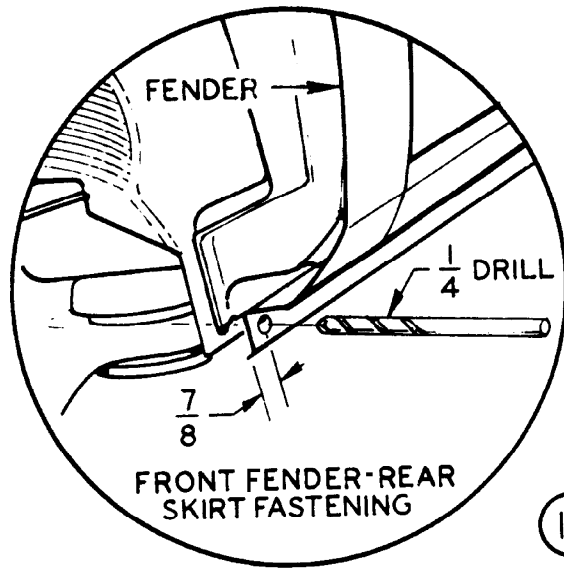

15

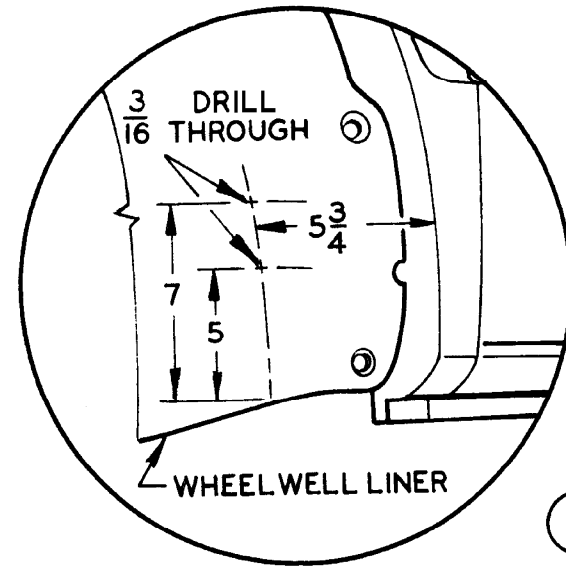

18

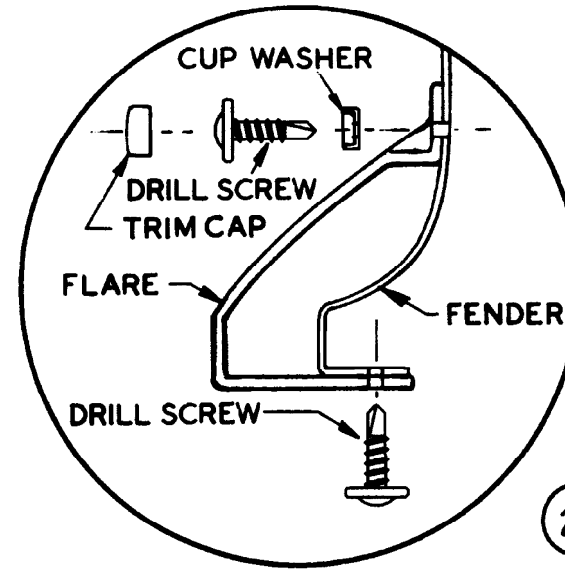

21

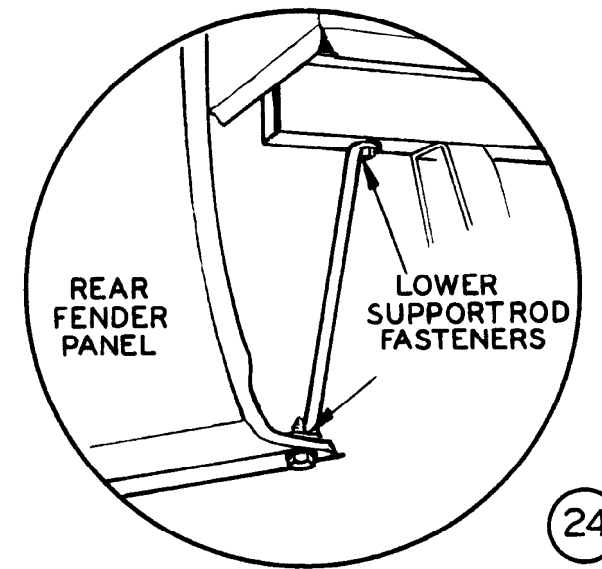

24

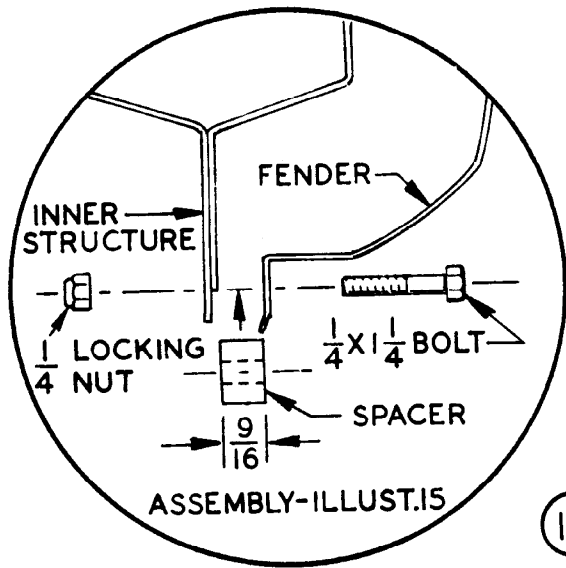

16

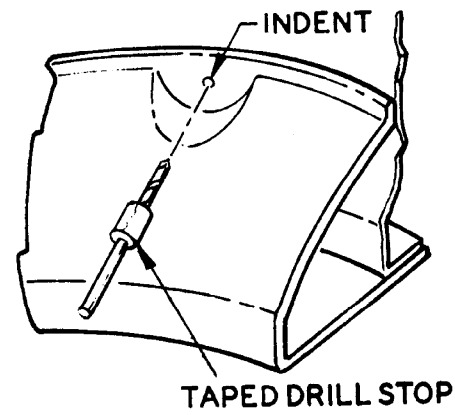

19

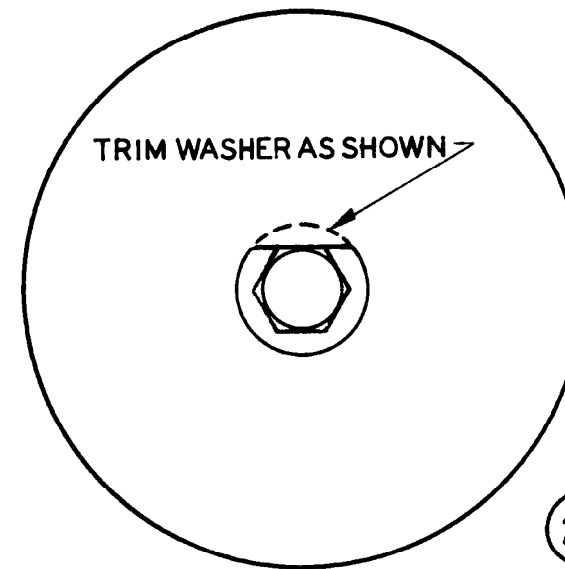

22

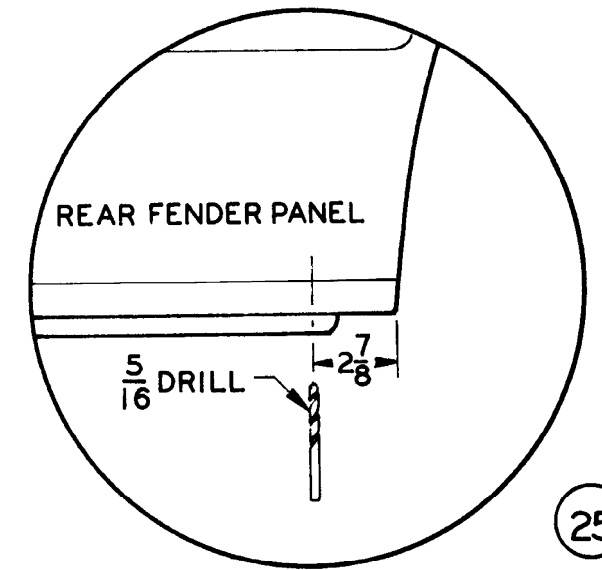

25

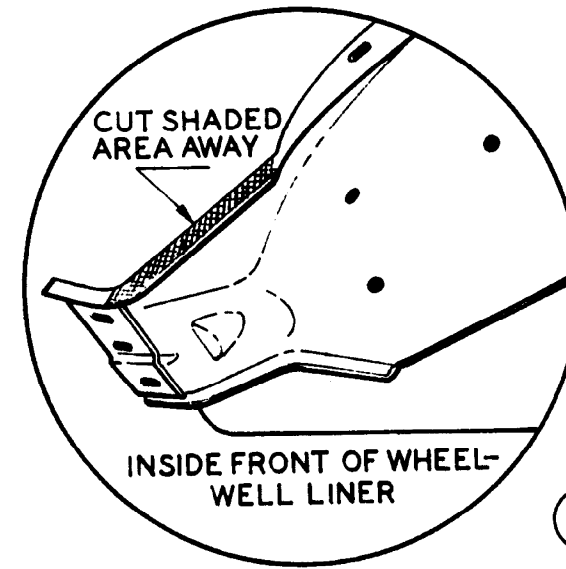

17

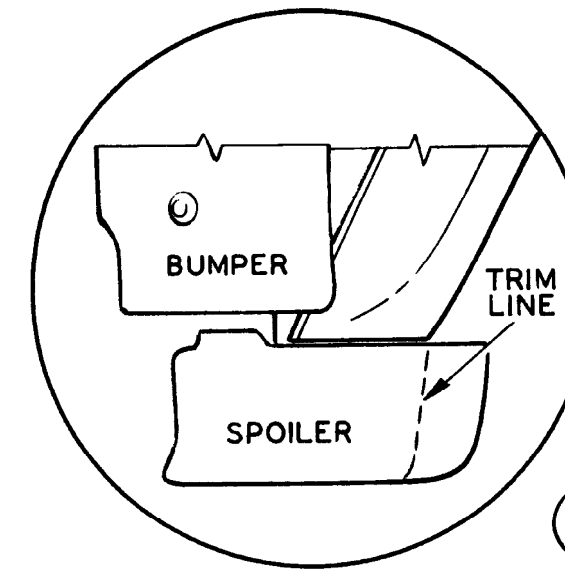
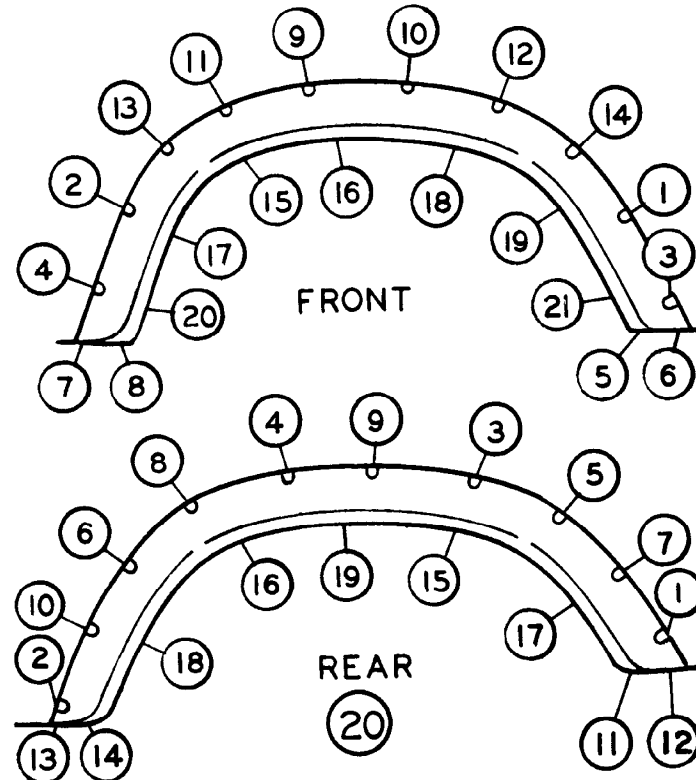

23

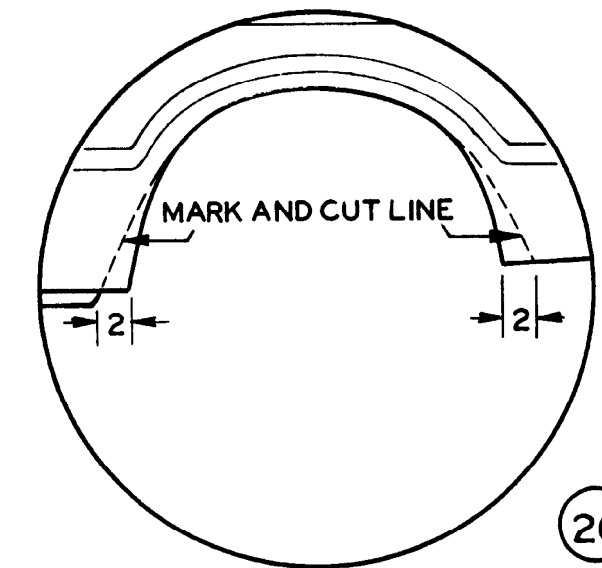

26