



INSTALLATION INSTRUCTIONS FOR BED RAIL CAPS, TAIL GATE CAP

TOOLS REQUIRED FOR INSTALLATION:

- Scissors
- Rubbing Alcohol
- Clean Cloth
- Grease Pencil

IMPORTANT: READ BEFORE BEGINNING INSTALLATION

Verifying Fit - Caps should be held to the vehicle surface to verify correct type and fit BEFORE beginning installation or painting. Small fit adjustments can be made by trimming (filing, sanding or scraping) excess plastic.

Ambient Temperature – During installation the vehicle, the parts to be installed, and the tape should be between 60° and 110°F for proper adhesion.

INSTALLATION PROCEDURES

Step 1: Painting

It is recommended that painting (when desired) be done prior to installation.

- (A) Sand (optional) before application of paint.
- (B) Clean outer surface with a good grade degreaser. DO NOT USE LACQUER THINNER OR ENAMEL REDUCER AS A DEGREASER. Wipe outer surface thoroughly with a tack rag prior to painting.
- (C) Paint caps using a high quality lacquer, enamel, or polyurethane automotive paint. Application of a primer coat is optional.

Step 2: Preparing the Work Area

- (A) Clean the vehicle surface in the area of installation.
- (B) Remove any excess wax or film from the vehicle surface with a clean cloth and rubbing alcohol.

Step 3: Tape Installation

- (A) Holding the parts in place on the vehicle, trace a line onto the outside of the tail gate and bed sides with a grease pencil, using the edge of the parts as a guide.
- (B) Apply a strip of tape along the length of the bed rail and tail gate 1/4" up from the grease pencil line marked along the vehicle. Trim the tape with scissors where the lines end. (See Illustration 1, Tape Strip A). Apply 30 lbs. of pressure per inch of tape for proper bond.

- (C) Apply a strip of tape to the length of the truck bed rails inside the bed. (See Illustration 2, Tape Strip C)
- (D) Apply a strip of tape across the top of the truck bed rail at the front edge by the cab. (See Illustration 1, Tape Strip B)
- (E) Apply strips of tape to the truck tail gate in the same areas as the bed rails.

Step 4: Part Installation

- (A) Peel two to three inches of red vinyl backing away from each end of the tape strips to provide a tail for pulling the rest of the backing free. (See Illustration 3)
- (B) Place the caps into position.
- (C) Starting with the inside rail, slowly pull the red vinyl backing free and press down on the cap as you continue to work your way down the rail. Apply 30 lbs. of pressure per inch of tape for proper bond.

Step 5: Front Cap Installation

- (A) Apply two strips of tape to the top surface of the sheet metal at the front of the bed, and peel off the red vinyl backing.
- (B) Carefully place the front cap into position on the vehicle and press into place.

Illustration 1

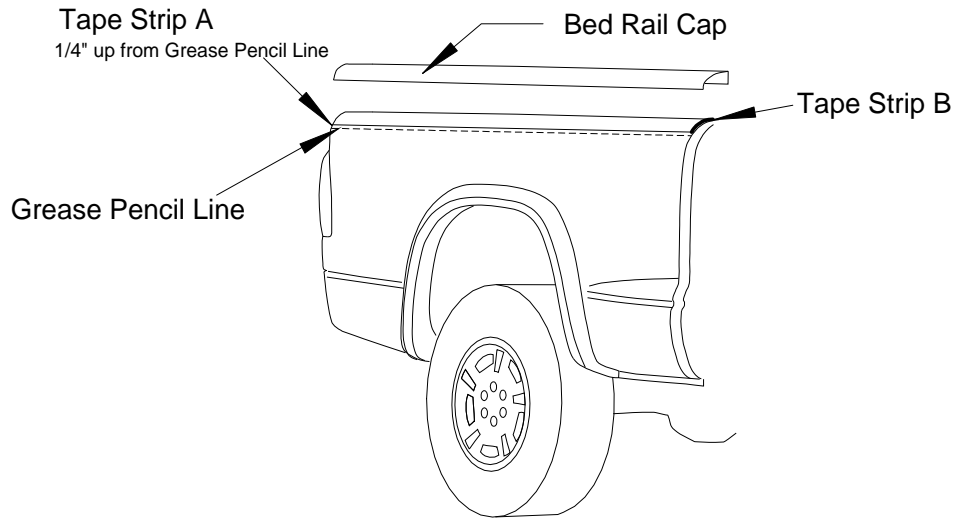

Illustration 2

Bed Rail Cross Section

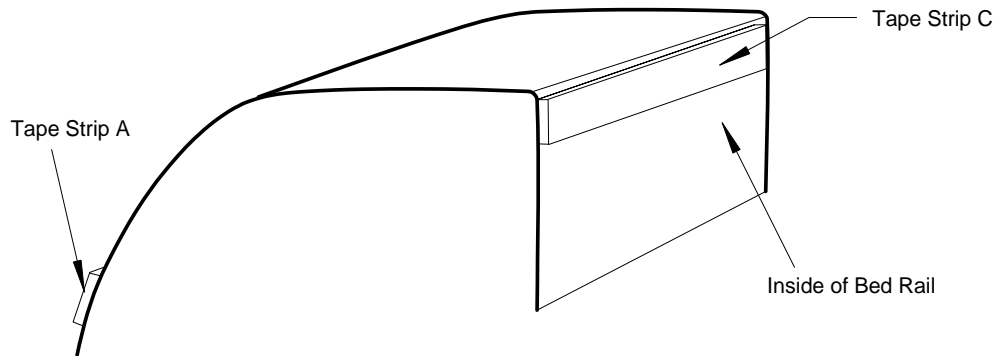

Illustration 3

