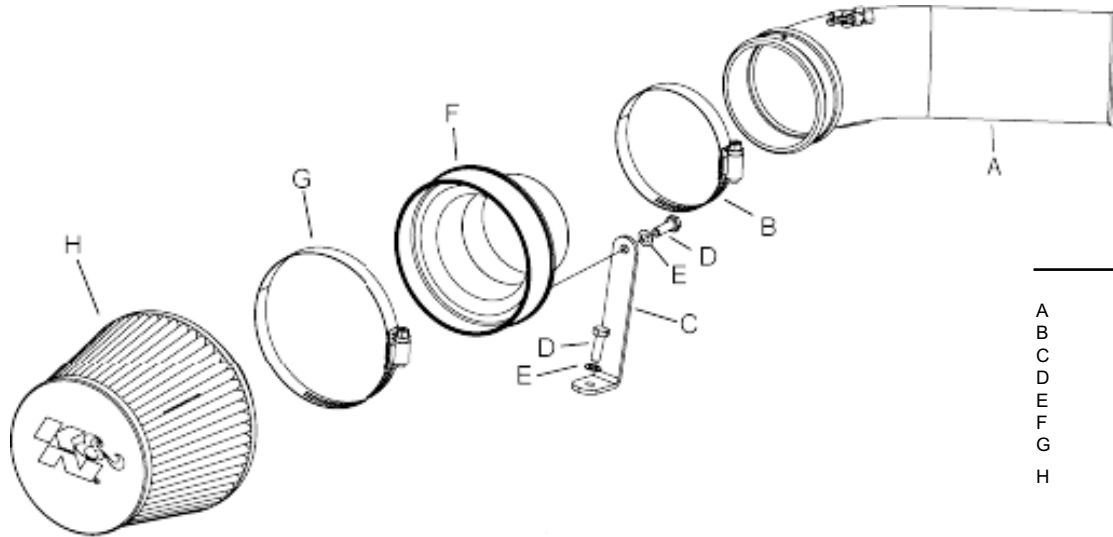

**INSTALLATION INSTRUCTIONS**
**57-3501**
**Acura**
**1990-93 Integra**
**L4-1.7-1.8L.**
**TOOLS NEEDED:**

 Ratchet, Extension, 10mm  
 Socket, Flat Blade Screw  
 Driver.

**PARTS LIST:**

Desc.	Qty.	Part #
A Intake Tube	1	08865
B Hose Clamp #48	1	08601
C Bracket; 57-3501, "L"	1	07066
D Bolt; 6MM-1.00 X 12MM	2	07863
E Washer; 6MM Wave	2	08174
F Adaptor; 4.5" OD.	1	08803
G Hose Clamp #72	1	08671
H Air Filter	1	RF-1005

**NOTE: FAILURE TO FOLLOW INSTALLATION INSTRUCTIONS AND NOT USING THE PROVIDED HARDWARE MAY DAMAGE THE INTAKE TUBE, THROTTLE BODY AND ENGINE.**

**TO START:**

1. Turn the ignition OFF and disconnect the vehicle's negative battery cable.



2. Unlatch the four air box lid retaining clips.



3. Lift the air box lid up; then, disconnect the stock intake tube from the air box lid.

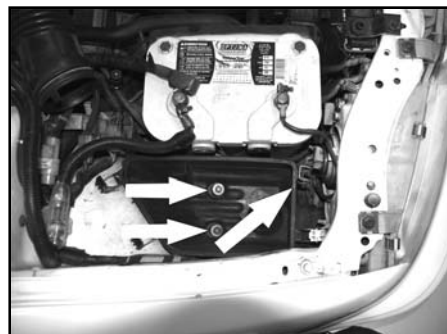

4. Remove the three bolts that secure the lower air box to the inner fender; then remove the lower air box from the vehicle.



5. Install the provided "L" bracket onto the filter adapter as shown; secure with provided hardware.



6. Install the filter adapter into the K&N intake tube; position as shown and secure with the provided hose clamp.

**Note: Do not completely tighten the hose clamp at this time as it will be necessary to submerge the end of the intake tube into hot water in order to enable the tube to slip over the filter adapter.**



7. Install the K&N intake assembly into the stock intake tube and align the "L" bracket with the rear inner air box mounting nut; located in the inner fender. Once the "L" bracket is aligned, secure with the provided hardware.

**Note: The connection of the K&N intake tube to the stock intake tube is very tight; this is normal. Also, do not tighten the mounting bolt at this time.**



8. Install the K&N filter onto the filter adapter; secure with the provided hose clamp. If needed, slightly adjust/move the "L" bracket at both the filter adapter and inner airbox mounting nut in order to obtain the best fit.

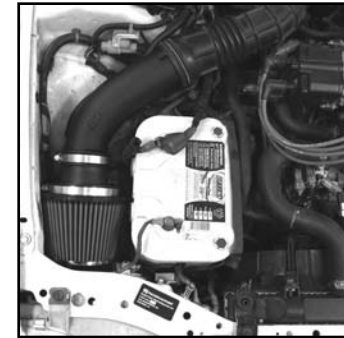

9. Reconnect the vehicle's negative battery cable. Double check to make sure everything is tight and properly positioned before starting the vehicle.

10. The C.A.R.B. exemption sticker must be visible under the hood so that an emissions inspector can see it when the vehicle is required to be tested for emissions. California requires testing every two years, other states may vary.

11. It will be necessary for all FIPK's to be checked periodically for realignment, clearance and tightening of all connections. Failure to follow the above instructions or proper maintenance may void warranty.

**ROAD TESTING:**

1. Start the engine with the transmission in neutral or park, and the parking brake engaged. Listen for air leaks or odd noises. For air leaks secure hoses and connections. For odd noises, find cause and repair before proceeding. This kit will function identically to the factory system except for being louder and much more responsive.

2. Test drive the vehicle. Listen for odd noises or rattles and fix as necessary.

3. If road test is fine, you can now enjoy the added power and performance from your kit.

4. K&N suggests checking the Air Filter element periodically for excessive dirt build-up. When the element becomes covered in dirt (or once a year), service it according to the instructions on the Recharger service kit, part number 99-5050 or 99-5000.